

Honeywell

Stryker™ BACnet Configurable Controllers

SPECIFICATION DATA

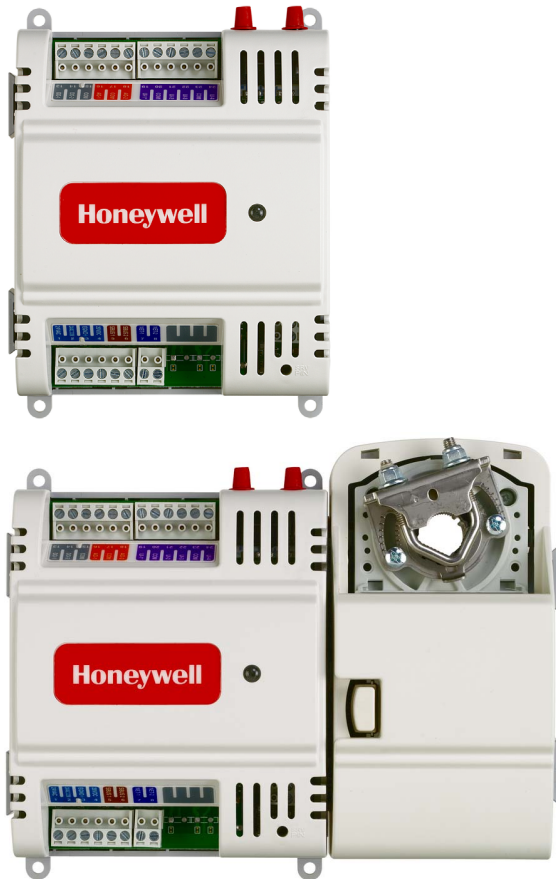

FEATURES

- Uses the BACnet MS/TP network protocol.
- EIA-485 communication network. Capable of baud rates between 9.6 and 115.2 kbits/s.
- Capable of stand-alone operation, but can also use BACnet network communications.
- Sylk™ bus for use with Sylk-enabled sensors.
- Support up to 30 controllers per BACnet MS/TP segment.
- Field configurable for control, input, and output functions using the NIAGARA FRAMEWORK® software.
- Built-in Zone Control functions include a remote wall module interface and a scheduler.
- Pressure-independent or pressure-dependent single Variable Air Volume (VAV) control.
- Microbridge air flow sensor with dual integral restrictor design.
- Easy user access to air flow sensor inputs.
- Actuator (CVB4022AS-VAV1 only) mounts directly onto VAV box damper shaft and has up to 44 lb-in. (5 Nm) torque, 90-degree stroke, and 90 second timing at 60 Hz.
- All wiring connections are made to removable terminal blocks to simplify controller installation and replacement.
- Both controller housing and actuator are UL plenum rated

GENERAL

The CVB4022AS-VAV1, and CVB4024NSVAV1 controllers are part of the Stryker family. The controllers are BACnet MS/TP network devices designed to control HVAC equipment. These controllers provide many options and advanced system features that allow state-of-the-art commercial building control. Each controller is configurable using the NIAGARA FRAMEWORK® software.

The controllers are for use in VAV (Variable Air Volume) control applications. Each controller provides flexible, universal inputs for external sensors, digital inputs, and a combination of analog outputs and digital outputs.



31-00100-03

DESCRIPTION

The configurable VAV/Unitary controllers are available as described in Table 1.

Table 1. Controller Configurations.

Controller Model	Programmable Type	Universal Inputs (UI)	Digital Inputs (DI)	Analog Outputs (AO)	Digital Outputs (DO)	Velocity Pressure Sensor (Microbridge)	Series 60 Floating Actuator
CVB4022AS-VAV1	VAV	4	0	2	2	YES	YES
CVB4024NS-VAV1	VAV	4	0	2	4	YES	NO

VAV Equipment Control

VAV controllers provide pressure-independent air flow control and pressure-dependent damper control. VAV systems generally provide cool air only to zones. However, each controller has additional programmable inputs and outputs that may be used to control devices, such as a fan or VAV box reheat coils. Heaters can be staged electric or modulating hot water. Supply and exhaust pressurization control are provided on a zone basis.

SPECIFICATIONS

Electrical

Rated Voltage: 20-30 Vac; 50/60 Hz

Power Consumption:

100 VA for controller and all connected loads (including the actuator on model CVB4022AS-VAV1)

Controller only Load: 5 VA maximum; model CVB4024NS-VAV1

Controller and Actuator Load: 9 VA maximum; model CVB4022AS-VAV1

External Sensors Power Output: 20 Vdc ±10% @ 75 mA maximum

Environmental

VAV Operating & Storage Temperature Ambient Rating: (Models CVL4022AS-VAV1 and CVL4024NS-VAV1)
Minimum 32° F (0° C); Maximum 122° F (50° C)

Dimensions (H/W/D)

See Fig. 1 and Fig. 2 beginning on page 6 for dimension drawings.

Approval Bodies

UL/cUL (E87741) listed under UL916 (Standard for Open Energy Management Equipment) with plenum rating.

CSA (LR95329-3) listed.

Meets FCC Part 15, Subpart B, Class B (radiated emissions) requirements.

Meets Canadian standard C108.8 (radiated emissions).

Conforms to the following requirements per European Consortium standards:

EMC Directive: 2014/30/EU:

Standards Applied:

- IEC 61000-4-8:2009
- IEC 61000-4-11:2004
- EN 61000-6-1: 2007; EN 61000-6-3:2007/A1:2011; EN 61000-6-3:2007/A1:2011/AC: 2012
- EN 60730-2-9: 2010, EN 60730-2-14: 1997 + EN60730-2-14/A1: 2001.
- In conjunction with EN 60730-2-9:2010 and in conjunction with EN 60730-2-14:1997 and amendments: EN 60730-1: 2000 + A1: 2004 + A16: 2007 + A2: 2008 -Annex H.26.

RoHS Directive: 2011/65/EU

Standards Applied:

- EN 50581: 2012

Regulatory Compliance Mark (RCM) declaration in Australia

BTL B-ASC (BACnet Testing Laboratories, BACnet Application Specific Controller)

Real Time Clock

Operating Range: 24 hour, 365 day, multi-year calendar including day of week and configuration for automatic daylight savings time adjustment to occur at 2:00 a.m. local time on configured start and stop dates

Power Failure Backup: 24 hours at 32 to 100° F (0 to 38° C), 22 hours at 100 to 122° F (38 to 50° C)

Accuracy: ±1 minute per month at 77° F (25° C)

Velocity Pressure Sensor

Operating Range: 0 to 1.5 in. H₂O (0 to 374 Pa)

Series 60 Floating Actuator

Rotation Stroke: 95° ± 3° for CW or CCW opening dampers
 Torque Rating: 44 lb-in. (5 Nm)
 Run Time for 90° rotation: 90 seconds at 60 Hz

Inputs and Outputs

Each controller has a combination of universal inputs (UI), digital inputs (DI), analog outputs (AO), and digital outputs (DO) as listed in Table 1.

Digital Input (DI) Circuits

Voltage Rating: 0 to 30 Vdc open circuit
 Input Type: Dry contact to detect open and closed circuit
 Operating Range: Open circuit = False; Closed circuit = True
 Resistance: Open circuit > 3,000 Ohms; Closed circuit < 500 Ohms

Digital Triac Output (DO) Circuits

Voltage Rating: 20 to 30 Vac @ 50-60Hz
 Current Rating: 25 mA to 500 mA continuous, 800 mA (AC rms) for 60 milliseconds

Analog Output (AO) Circuits

Analog outputs can be individually configured for current or voltage.

ANALOG CURRENT OUTPUTS:

Current Output Range: 4.0 to 20.0 mA
 Output Load Resistance: 550 Ohms maximum

ANALOG VOLTAGE OUTPUTS:

Voltage Output Range: 0 to 10.0 Vdc
 Maximum Output Current: 10.0 mA

Analog outputs may be configured as digital outputs and operate as follows:

- False (0%) produces 0 Vdc, (0 mA)
- True (100%) produces the maximum 11 Vdc, (22 mA)

Universal Input (UI) Circuits

See Table 2 for the UI specifications.

Table 2. Universal Input Circuit Specifications.

Input Type	Sensor Type	Operating Range
Room/Zone Discharge Air Outdoor Air Temperature	20K Ohm NTC	-40° F to 199° F (-40° C to 93° C)
Outdoor Air Temperature	C7031G ^a	-40° to 120°F (-40° to 49°C)
	C7041F ^a	-40° to 250°F (-40° to 121°C)
	PT1000 (IEC751 3850)	-40° F to 199° F (-40° C to 93° C)
TR23 Setpoint Potentiometer	500 Ohm to 10,500 Ohm	-4° DDC to 4° DDC (-8° DDF to 7° DDF) or 50° F to 90° F (10° C to 32° C)
Resistive Input	Generic	100 Ohms to 100K Ohms
Voltage Input	Transducer, Controller	0-10 Vdc
Discrete Input	Dry Contact closure	OpenCircuit ≥ 30000hms ClosedCircuit < 30000hms

^a C7031G and C7041F are recommended for use with these controllers, due to improved resolution and accuracy when compared to the PT1000.

Hardware

CPU

Each controller uses a 32 bit ATMEL ARM 7 microprocessor.

Memory Capacity

Flash Memory: 512 kilobytes. The controller is able to retain Flash memory settings for up to ten (10) years.

RAM: 128 kilobytes

Controller Status LED

The LED on the front of the controller provides a visual indication of the status of the device. When the controller receives power, the LED appears in one of the following allowable states, as described in Table 3.

Table 3. Status LED States.

LED State	Blink Rate	Status or Condition
OFF	not applicable	No power to processor, LED damaged, low voltage to board, or controller damaged.
ON	ON steady; not blinking	Processor and/or controller is not operating.
Very slow blink (continuous)	1 second ON, 1 second OFF	Controller is operating normally.
Slow blink (continuous)	0.5 second ON, 0.5 second OFF	Controller alarm is active, controller in process of download, or controller lost its configuration.
Medium blink (continuous)	0.25 second ON, 0.25 second OFF	Controller firmware is loading.
Fast blink (continuous)	0.10 second ON, 0.10 second OFF	Controller is in manual mode under control of the PC-based software tool.

BACNET STATUS LED:

The LED on the front of the controller, between the BACnet MS/TP terminals and MAC Address DIP Switches, provides a visual indication of the BACnet MS/TP communication status. When the controller receives power, the LED appears in one of the following allowable states, as described in Table 4.

Table 4. BACnet Status LED States.

BACnet LED Status	Status or Condition
Solid on	Controller has power, loader is not running.
Solid on, blinking off once in 2.5 sec.	Controller is in reflash mode, no MS/TP communication.
Solid on, blinking off twice in 2.5 sec.	Controller is in reflash mode, MS/TP communication present.
Solid on, blinking off three times in 2.5 sec.	Controller is in reflash mode, MS/TP communication data transfer in progress.
Solid off, there is no power	No power to processor, LED damaged, low voltage to board, or loader damaged.
Solid off, blinking on once in 2.5 sec.	Controller is running, no MS/TP communication.
Solid off, blinking on twice in 2.5 sec.	Controller is running, MS/TP communication present.
Solid off, blinking on three times in 2.5 sec.	Controller is running, MS/TP communication data transfer in progress.

Communications

Each controller uses a BACnet MS/TP communications port. The controller's data is presented to other controllers over a twisted-pair MS/TP network, which uses the EIA-485 signaling standard capable of the following baud rates: 9.6, 19.2, 38.4, 76.8, or 115.2 kilobits per second (configured at global controller). The Stryker BACnet controllers are master devices on the MS/TP network. Each Stryker BACnet controller uses a high-quality EIA-485 transceiver and exerts 1/4 unit load on the MS/TP network.

Cabling should be selected that meets or exceeds the BACnet Standard which specifies the following: an MS/TP EIA-485 network shall use shielded, twisted-pair cable with characteristic impedance between 100 and 130 ohms. Distributed capacitance between conductors shall be less than 100 pF per meter (30 pF per foot). Distributed capacitance between conductors and shield shall be less than 200 pF per meter (60 pF per foot). Foil or braided shields are acceptable. The Honeywell tested and recommended MS/TP cable is Honeywell Cable 3322 (18 AWG, 1-Pair, Shielded, Low Cap, Plenum cable), alternatively Honeywell Cable 3251 (22 AWG, 1-Pair, Shielded, Plenum cable) is available and meets the BACnet Standard requirements (www.honeywellcable.com).

The BACnet MS/TP network is polarity sensitive. The maximum BACnet MS/TP network Bus segment length is 4,000 ft. (1,219 m) using recommended wire. Repeaters must be used when making runs longer than 4,000 ft. (1,219 m). A maximum of three repeaters can be used between any two devices.

MS/TP MAC Address

The MS/TP MAC address for each device must be set to a unique value in the range of 0-127 on an MS/TP network segment. DIP switches on the Stryker BACnet controller are used to set the controller's MAC address.

Device Instance Number

The Device Instance Number must be unique across the entire BACnet system network because it is used to uniquely identify the BACnet devices. It may be used to conveniently identify the BACnet device from other devices during installation. The Stryker BACnet Controllers Device Instance Number is automatically set when it is added to a WEBStation-AX project. The Device Instance Number can be changed by the user, which may be necessary when integrating with a third party or when attempting to replace an existing controller and it is desired to maintain the existing Device Instance Number.

Termination Resistors

Matched terminating resistors are required at each end of a segment bus wired across (+) and (-). Use matched precision resistors rated 1/4W ±1% / 80 - 130 Ohms. Ideally, the value of the terminating resistors should match the rated characteristic impedance of the installed cable. For example, if the installed MS/TP cable has a listed characteristic impedance of 120 Ohm, install 120 Ohm matched precision resistors.

NOTE: The controller does not provide any network biasing.

Shield Terminating

Following proper MS/TP cabling shield grounding procedures is important to minimize the risk of communication problems and equipment damage caused by capacitive coupling. Capacitive coupling is caused by placing MS/TP cabling close to lines carrying higher voltage. The shield should be grounded on only one end of the MS/TP segment (typically the router end). Tie the shield through using the SHLD (terminal 4) on the Stryker BACnet Controller.

Sylk™ Bus

Sylk is a two wire, polarity insensitive bus that provides both 18 VDC power and communications between a Sylk-enabled sensor and a Sylk-enabled controller. Using Sylk-

enabled sensors saves I/O on the controller and is faster and cheaper to install since only two wires are needed and the bus is polarity insensitive. Sylk sensors are configured using the latest release of the Stryker Tool for WEBPro and WEBStation.

Accessories

- TR71/75 Zio LCD Wall Module
- 201052A,B,C Auxiliary Switches (one, two or three switches)
- C7041B,C,D,P,R Air Temperature Sensor (indoor)
- C7770A Air Temperature Sensor (indoor/plenum)
- C7031G Air Temperature Sensor (outdoor)
- C7041F Air Temperature Sensor (outdoor)
- Q7751A,B Router (configured as a repeater)
- TR71/75 Zio Wall Module
- TR2X Wall Module
- C7400A Enthalpy Sensor
- P7640 Pressure Transducer Family
- C7232 CO₂ Sensor Family
- C7600 Humidity Sensor Family
- H7625, H7635, and H7655 Humidity and Temperature Sensors

Refer to the “Sensors Product Overview,” form 63-9285, for additional accessories.

Mounting

The controller enclosure is constructed of a plastic base plate and a plastic factory-snap-on cover. The cover does not need to be removed from the base plate for either mounting or wiring. Removable terminal blocks are used for all wiring connections, which allow the controller to be wired before or after mounting.

The controller can be mounted in any orientation. Ventilation openings are designed into the cover to allow proper heat dissipation regardless of the mounting orientation.

NOTE: The controller must be mounted in a position that allows clearance for wiring, servicing, removal, connection of the LONWORKS® Bus Jack, and access to the NEURON® Service Pin.

NOTE: For complete mounting information, refer to the “Installation Instructions,” form 31-00101-01.

CVB4022AS-VAV1 Mounting (Controllers with actuators)

The CVB4022AS-VAV1 controller includes the direct-coupled actuator with Declutch mechanism, which is shipped hard-wired to the controller.

The actuator mounts directly onto the VAV box damper shaft and has up to 44 lb-in. (5 Nm) torque, 90-degree stroke, and 90 second timing at 60 Hz. The actuator is suitable for mounting onto a 3/8 to 1/2 in. (10 to 13 mm) square or round VAV box damper shaft. The minimum VAV box damper shaft length is 1-9/16 in. (40 mm).

After the actuator is mounted onto the damper shaft, the controller mounts to a panel by using four No. 6 or No. 8 machine or sheet metal screws inserted through the corners of the base plate.

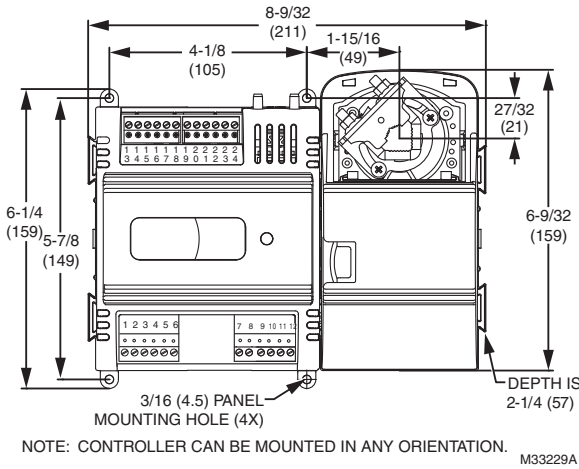

Fig. 1. Panel mounting—controller and actuator dimensions in inches (mm) for CVB4022AS-VAV1 only.

CVB4024NS-VAV1—Mounting (Controllers with actuators)

The CVB4024NS-VAV1 controller mounts to either a panel or DIN rail (standard EN50022; 7.5mm x 35mm).

- For panel mounting, use four No. 6 or No. 8 machine or sheet metal screws inserted through the corners of the base plate.
- For DIN rail mounting, refer to the “Installation Instructions,” form 31-00101-01.

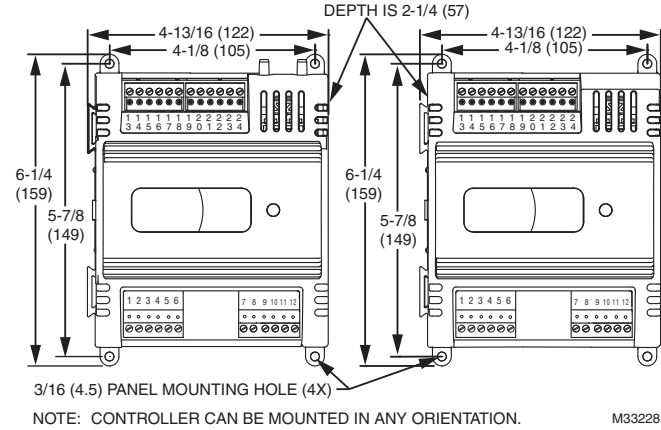

Fig. 2. Panel mounting—controller dimensions in inches (mm) for CVB4024NS-VAV1 only.

By using this Honeywell literature, you agree that Honeywell will have no liability for any damages arising out of your use or modification to, the literature. You will defend and indemnify Honeywell, its affiliates and subsidiaries, from and against any liability, cost, or damages, including attorneys' fees, arising out of, or resulting from, any modification to the literature by you.

Automation and Control Solutions

Honeywell International Inc.
1985 Douglas Drive North
Golden Valley, MN 55422
customer.honeywell.com

® U.S. Registered Trademark
© 2016 Honeywell International Inc.
31-00100-03 M.S. Rev. 10-16
Printed in United States

Honeywell